



**Calypso  
LINE STAGE**

Aesthetix Audio Corporation  
5220 Gabbert Rd. Suite A ♦ Moorpark, CA. 93021 USA  
Phone: (805) 529-9901

## **INTRODUCTION**

Thank you for purchasing the Calypso Line Stage. The Calypso is a groundbreaking audio component which combines sonic quality, innovative features and build quality with lineage directly traceable to the reference Callisto stage. Calypso contains solid state circuitry but all of its amplification is achieved using vacuum tubes. The output stage is a vacuum tube based differential driver. There is no global feedback used in the Calypso.

Calypso's advanced microprocessor-based control circuitry is completely inactive when not in use i.e. when not receiving a command from the user, resulting in no ill effects on sound quality. The unit contains innovative features, such as a switched resistor volume control, theater bypass mode, phase inversion and others.

The massive power supply consists of a high voltage transformer, heater transformer, and high voltage choke. All of the magnetic components are shielded by a stainless steel transformer cover, which also performs double duty as a structural truss. The high voltage power supply is regulated with a discrete transistor-based regulator. The low voltage solid state power supplies are discretely regulated.

Only the highest quality components are used in the Calypso, including Roederstein resistors, RelCap film capacitors, (Dynamicap in the Signature and Stealthcap™ in the Eclipse editions), Custom transformers and Nichicon audio grade electrolytic capacitors.

We hope you enjoy many years of music using the Calypso line stage.

## **PLACEMENT**

Calypso should be located away from possible sources of hum such as power cords, power transformers and the like.

Ventilation is critical for reliability. It should not be located on top of any heat source such as a power amplifier. If it is positioned within an enclosed space then fans may be warranted. All air vents must remain unobstructed. A minimum of 3 inches of space above the unit is required.

## **CONNECTIONS**

**Important:** Ensure the rear panel power switch is in the off position whenever changing connections. Also ensure that the power amplifier is off.

- 1) Connect one or more source components to the Calypso's inputs. Both balanced and single-ended connections are provided for each input. A tape deck may be connected to the tape input / output connectors. The tape output is unbuffered.
- 2) Using either the single-ended (RCA) or balanced (XLR) outputs, connect the Calypso to your power amplifier. Use of balanced connections will yield 6dB more gain.
- 3) Connect the supplied IEC power cord to the back of the Calypso and to an unswitched, grounded AC outlet. Line conditioners may be used with the unit if desired. Ensure the maximum power of the conditioner is not being exceeded.

Note: The input circuitry of the Calypso accepts a maximum input voltage of 3.5v rms single-ended or 7v rms balanced. This is well above the industry standard 2v rms single-ended or 4v rms balanced. However, there are a few source components that exceed this limit. If the offending source component has a volume or gain control, all that is necessary is to reduce the gain or volume of the source component. In other cases, it will be necessary to have the source component modified to be within industry standard specifications. A clear indication that this limit is being exceeded is a raspy distortion or compression of musical peaks.

## **OPERATION**

### **STANDBY**

AC power is applied to the unit by pressing on the left side of the power switch, when viewed from the front of the unit. When Calypso has power applied for the first time, it will first display the installed software version on the LED display for two seconds, then automatically enter the standby mode. While in standby, power is applied to all circuits except the vacuum tube heaters. The high voltage supply is reduced to a level that is safe for the vacuum tubes. All solid state circuitry in the Calypso remains powered. Anytime Calypso is in standby, the standby light will be illuminated.

Pressing the standby button will take Calypso out of standby. The standby light will blink for 30 seconds, during which time the heater supplies will be energized and the high voltage supply will rise to operational levels. After the warm-up period, the standby light will extinguish and the input will be displayed, and the mute light will be illuminated indicating the Calypso is muted.

Place Calypso in standby when not in use.

### **INPUT SELECTION**

Press any of the five input selection buttons to select the desired input. Tape input selection will monitor the output from a cassette deck.

## **VOLUME**

Volume is controlled by pressing the left side of the display lens for down, the right side for up. Each step is 1dB.

## **BALANCE**

Balance is adjusted only by the remote control, by the left and right arrow buttons. It is not adjustable from the front panel. When the unit is adjusted to be out of balance, two volume numbers will display. The left indicates the left channel volume number, the right indicates the right channel volume number. When both channels are set to the same number, the display will change to only show one number. The balance will shift up to 9 steps in either direction and the 10<sup>th</sup> step will be off, indicated by 00.

## **MUTE**

Pressing the mute button will alternately mute or unmute the unit. When the mute light is illuminated, the Calypso is muted. When muted, the volume is internally set to zero and the output is shorted to ground.

## **BYPASS**

Bypass is used to set the unit to unity gain (meaning it does not provide any gain or loss). This is used when a home theater processor is connected to the Calypso, and system control is delegated entirely to the processor. Extreme caution is necessary, as setting the Calypso to unity gain will, in most system, allow the full input level to reach the power amplifier. This can damage speakers.

When in bypass, all of Calypso's normal circuitry is in use, including the tubes.

One or more inputs may be configured for bypass. Once configured for bypass, that input will automatically go into bypass mode every time it is selected. Once in bypass mode, there is no volume display or function and mute is non-functional.

Follow these steps to configure an input for bypass:

- 1) Select desired input.
- 2) On the front panel only (not remote control), depress the bypass button and hold it in the depressed position. The bypass LED will light.
- 3) While holding the bypass button, press the input button again. Both the bypass and selected input LEDs will blink rapidly, indicating the unit recognized the desired bypass configuration.

The unit will enter bypass mode as indicated by the bypass LED and lack of volume display. Selecting another input that has not been configured for bypass will exit the bypass mode. Selecting an input that is configured for bypass will cause the bypass LED to blink for a short time before going to the desired input, indicating that the unit is about to enter the bypass mode. This is to allow the user time to reduce the level of the surround processor or select another input if there is any doubt about the safety of entering bypass mode. Pressing any button on the Calypso while the bypass LED is blinking will cause the unit to revert back to the last selected input.

To remove the bypass configuration for a selected input, follow the same procedure as above.

The tape input may also be configured for bypass. The procedure is the same as above, except holding the tape input button instead of the currently selected input. Tape must be pre-selected. A special feature of using the tape input as the bypass input is that high quality analog sources can be kept in their purest form for two channel listening through the Calypso, or routed through the surround processor when desired, by selecting tape. The tape output of the Calypso, in that case, should be routed to an input of the surround processor.

Bypass configurations are stored in memory and are retained even if power is removed. For this reason, it is recommended to remove all bypass configurations if the unit is ever transferred from one system to another, to prevent possible system damage.

**Changing the Bypass Level:**

When in bypass, the volume level is not displayed. However, internally there is a volume level that is used when in bypass.

The factory default bypass level is 71, which is unity gain when the internal gain jumpers are set to -12dB and the balanced inputs / outputs are used. The bypass level can be changed for different input/output choices and internal gain jumper settings. The chart below indicates unity gain for different configurations:

<b>Input</b>	<b>Output</b>	<b>Internal Gain</b>	<b>Unity Gain</b>
SE In ⇒ SE Out		0dB	64
Bal In ⇒ Bal Out		0dB	58
SE In ⇒ Bal Out		0dB	58
Bal In ⇒ SE Out		0dB	64
SE In ⇒ SE Out		-12dB	77
Bal In ⇒ Bal Out		-12dB	71
SE In ⇒ Bal Out		-12dB	71
Bal In ⇒ SE Out		-12dB	77

To change the Bypass level, from the front panel, press and hold the DISPLAY button, then press button #4. Release both buttons. The current bypass level will be displayed. Use UP and DOWN (left and right side of the display or UP and DOWN arrows on the remote) to adjust. When the currently selected input is in Bypass mode, the sound level will go up and down when adjusting.

**PHASE**

The phase button is used to change the absolute phase of the output. When the phase LED is illuminated, the output is 180 degrees out of phase relative to the input. When the LED is off, the output is 0 degrees. The correct setting is that which yields the best focus of image and tightest bass. It will vary from recording to recording, as absolute phase is rarely maintained throughout the recording and mastering process.

## DISPLAY

In normal operation, the level setting is displayed and various indicator lights will be illuminated. When the display button is pressed, all lights will extinguish. Pressing any button will turn on the display and indicator lights for 5 seconds, and then extinguish. The only exception is standby, which will always have the standby light illuminated.

Pressing the display button while the display is off, or during the 5 second timeout period, will turn on the display and normal operation will return.

<b>Note:</b> The LED for the display button is intentionally inactive.
--

### Advanced display functionality

This unit contains the ability to sense the ambient light level in the room and adjust the display and LEDs accordingly. While the factory settings will work for most situations, there may be times when adjustment to the settings is useful. There are three main sections to the advanced display functionality:

- Adjustment of display brightness
- Adjustment of LED brightness
- Restoration of the factory default settings

#### **Adjustment of display brightness:**

To access this section, first press and hold the “display” button, then concurrently press “1” button. This can only be done from the front panel. It is recommended that once this section is entered, that all adjustments be made with the remote at some distance from the unit, so as not to obstruct light from reaching the sensor. LED #2 will light, and the display will show two numbers in the range 00-15, one on the left display and one on the right display. The left number indicates the light level that the sensor is reporting, 0 is darkest and 15 is brightest. The rightmost number indicates the display brightness setting for that light level, 0 is darkest and 15 is brightest. LED#2 will be lit, which indicates that pressing the “up” or “down” buttons will adjust the display brightness for the current light level. Pressing button #1 will turn on LED#1, which indicates that pressing the “up” or “down” buttons will change to a different light level setting, for which the display brightness could then be changed by pressing button #2. Changes to the display brightness will only be visible for the current light level.

To exit this section, press the “display” button.

### **Adjustment of LED brightness:**

This section works identically to the above “Adjustment of display brightness” except that adjustment is made to the LED brightness instead of the display.

To access this section, first press and hold the “display” button, then concurrently press “2” button. This can only be done from the front panel. It is recommended that once this section is entered, that all adjustments be made with the remote at some distance from the unit, so as not to obstruct light from reaching the sensor. LED #2 will light, and the display will show two numbers in the range 00-15, one on the left display and one on the right display. The left number indicates the light level that the sensor is reporting, 0 is darkest and 15 is brightest. The rightmost number indicates the LED brightness setting for that light level, 0 is darkest and 15 is brightest. LED#2 will be lit, which indicates that pressing the “up” or “down” buttons will adjust the LED brightness for the current light level. Pressing button #1 will turn on LED#1, which indicates that pressing the “up” or “down” buttons will change to a different light level setting, for which the LED brightness could then be changed by pressing button #2. Changes to the LED brightness will only be visible for the current light level.

To exit this section, press the “display” button.

#### **Special note:**

Setting all brightness levels to the same value, for all light levels, will result in no change of display or LED brightness with changes in ambient light level in the room.

### **Restoration of the factory default settings:**

To restore the factory settings for all display settings, first press and hold the “display” button, then concurrently press the “3” button. This can only be done from the front panel. LEDs 1-5 will light, indicating that the unit has restored the factory settings.

## Maintenance

Do not, under any condition, remove the top cover while the AC power cord is connected to the unit. As the power supply remains charged even with power removed, wait at least 20 minutes after removing the AC power cord before attempting any maintenance.

Under normal conditions, internal access is not required. In the event of a noisy tube or other maintenance, the top cover may be removed. There are no screws, it is securely held in place by an advanced polymer interlocking material. To remove the top cover, grasp it at the rear left edge and pull up firmly. The interlocking material will gradually disengage as the top cover is “peeled” up.

To reinstall the top cover, align the front edge with the back of the faceplate and gradually press down, starting at the front and moving toward the back.

### **Internal Gain Adjustment**

The Calypso is a high gain linestage. Audio systems with efficient speakers and / or sensitive amplifiers may require less gain. One indication would be a low volume control range, i.e. 0-30 for normal listening level. Another is excessive tube hiss from the Calypso. If there is excessive tube hiss and the volume range is greater than 30, likely the tubes are the problem and the vacuum tube troubleshooting guide should be consulted. If it is determined that a lower gain setting is desirable, the following procedure details a –12dB gain reduction. Reducing the gain by 12dB will also reduce tube hiss by 12dB.

#### Procedure:

1. Disconnect the AC power cord from the Calypso.
2. Wait a full 20 minutes for the power supply to drain to safe levels.
3. Remove the top cover.
4. Locate the jumper blocks shown in the diagram on the following page.
5. There are 2 choices of gain setting: either 0dB or –12dB. There are 2 shunts per channel. The 2 shunts need to be on the outside positions for 0dB or on the 2 inside positions for –12dB. Set them both according to the requirements.
6. Repeat the above step for the other channel.
7. Replace the top cover.



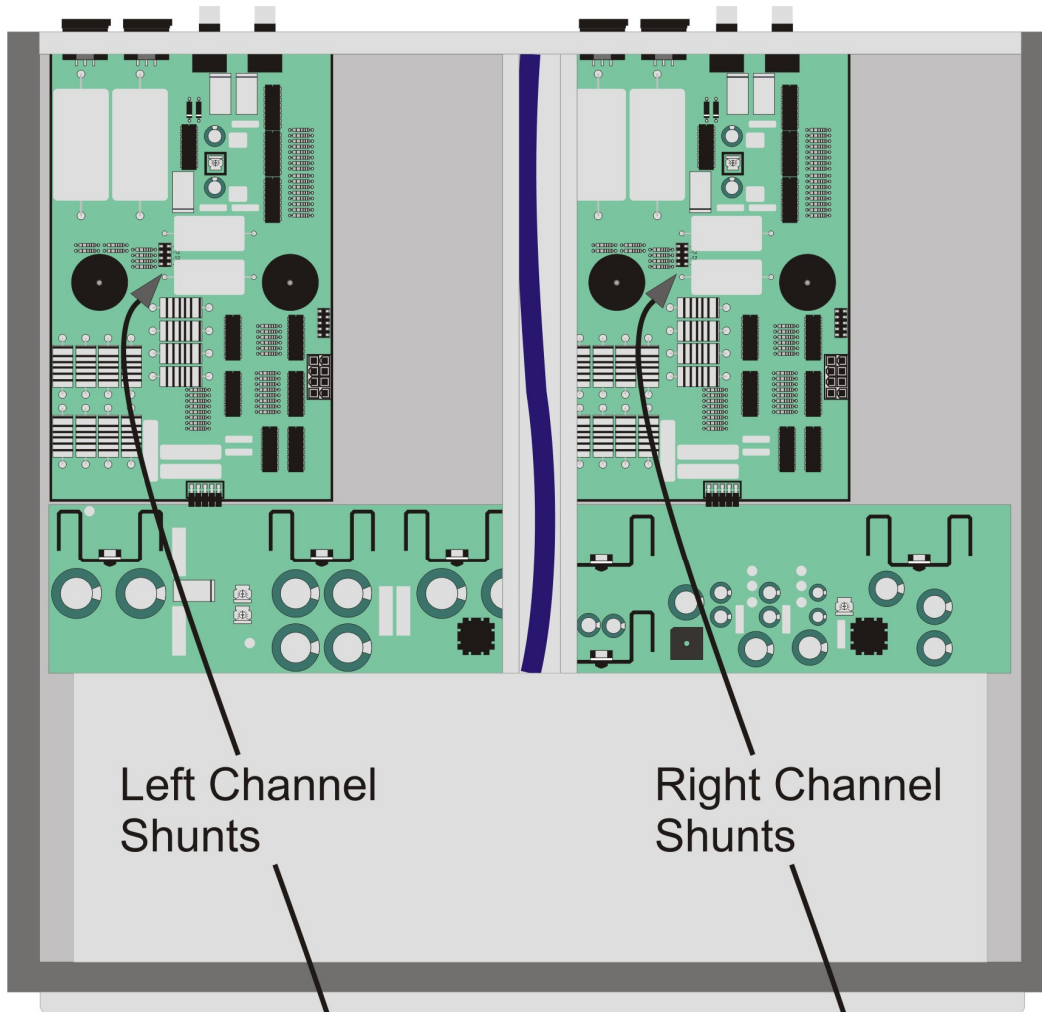

Left Channel Shunts

Right Channel Shunts

Left at 0dB

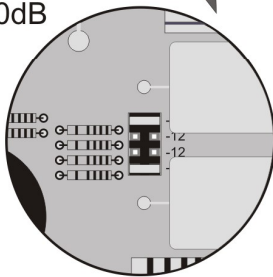

Right at 0dB

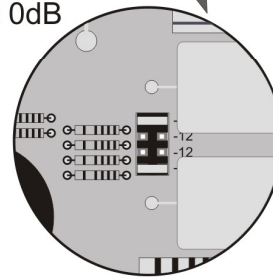

----- or -----

Left at -12dB

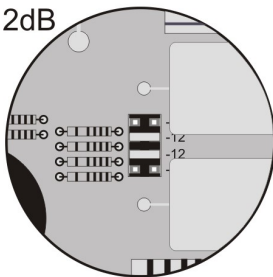

Right at -12dB

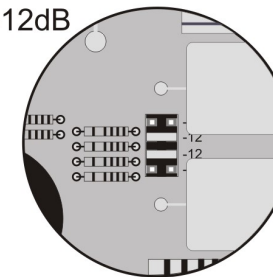

## Specifications

### Outputs:

Main : 2 Balanced XLR and 2 single-ended per channel  
Tape Out: 1 single-ended per channel

### Output Impedance

Single-Ended 1K ohms  
Balanced 300 ohms

### Input Impedance

Single-Ended 20K  
Balanced 40K

### Fuses:

External fuse (in IEC power connector)      2 amp slow blow (117v)  
   1 amp slow blow (230v)  
Spare fuse included in IEC power connector.

### Tubes:

V1 12AX7 Very low noise, level matched & non-microphonic.  
V2 6922 (6DJ8) Unmatched, no noise.

### Power Consumption:

Standby: 20 watts  
Active: 100 watts

### Dimensions:

18" Width x 17 5/8" Depth x 4 3/8" Height

### Shipping Weight:

40 lbs (18.2Kg)

90 DAY LIMITED WARRANTY TERMS AND CONDITIONS  
(3 Year optional extended service contract)

1. Aesthetix warrants the product designated herein to be free of manufacturing defects in material and workmanship, subject to the conditions herein set forth, for a period of 90 days from the date of purchase by the original purchaser. If the purchaser registers the unit with Aesthetix by mailing in the warranty card, together with a copy of the bill of sale, within 14 days of the date of purchase, said purchaser will be registered for an extended service contract. The extended service contract extends the 90 days to a period of 3 years from the date of purchase by the original purchaser or no later than 4 years from the date of shipment to the authorized Aesthetix dealer, whichever comes first. The warranty period for factory tubes does not get extended and therefore remains at 90 days.

2. **CONDITIONS**

This warranty is subject to the following conditions and limitations. The warranty is void and inapplicable if the product has been used or handled other than in accordance with the instructions in the owner's manual, abused or misused, damaged by accident or neglect or in being transported, or the defect is due to the product being repaired or tampered with or modified by anyone other than Aesthetix. The product must be packed and returned to Aesthetix by the customer at his or her sole expense. A returned product must be accompanied by a written description of the defect and a photocopy of the original purchase receipt. This receipt must clearly list model and serial number, the date of purchase, the name and address of the purchaser and authorized dealer and the purchase price. Aesthetix reserves the right to modify the design of any product without obligation to purchasers of previously manufactured products and to change the prices or specifications of any product without notice or obligation to any person.

3. **REMEDY**

In the event the above product fails to meet the warranty, and the above conditions have been met, the purchaser's sole remedy under the limited warranty shall be to return the product to Aesthetix where the defect will be rectified without charge for parts or labor.

4. **LIMITED TO ORIGINAL PURCHASER**

This warranty is for the sole benefit of the original purchaser of the covered product and shall not be transferred to a subsequent purchaser of the product.

5. **DURATION OF WARRANTY**

This warranty expires 90 days after the date of original purchase. If Aesthetix receives the warranty registration card, this period is extended to the third anniversary of the date of purchase or no later than the fourth anniversary of the shipment to the authorized Aesthetix dealer, whichever comes first.

6. **MISCELLANEOUS**

ANY IMPLIED WARRANTIES RELATING TO THE ABOVE PRODUCT SHALL BE LIMITED TO THE DURATION OF THIS WARRANTY. THE WARRANTY DOES NOT EXTEND TO ANY INCIDENTAL OR CONSEQUENTIAL COSTS OR DAMAGES TO THE PURCHASER. Some states do not allow limitations on how long an implied warranty lasts or an exclusion or limitation of incidental or consequential damages, so the above limitations or exclusions may not apply to you. This Warranty gives you specific legal rights, and you may also have other rights which vary from state to state.

7. **WARRANTY OUTSIDE THE USA**

Aesthetix has formal distribution in many of the countries of the free world, in each country the Aesthetix importer has contractually accepted the responsibility for product warranty. Warranty should normally be obtained from the importing dealer or distributor from whom you obtain your product.